

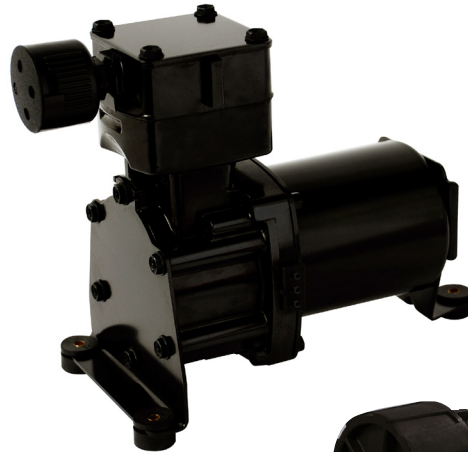

309 SERIES

MODELS

309CDC56/12
309DDC56/12



309CDC Series



309DDC Series

FEATURES

- Oil-less
- Die cast aluminum components
- Steel mounting brackets with vibration isolators
- Stainless steel inlet valve
- PTFE piston ring
- Thermally protected motor
- Intermittent duty only
- All wetted aluminum parts treated for corrosion protection from moisture
- Radiated Emissions Suppression

Consult factory for custom applications

Thomas Division is an ISO 9001 registered company

THOMAS
A Gardner Denver Product

USAThomas.com

(800) 799-4568 | 3810 Prospect Ave, Ste. A, Yorba Linda, CA 92886

309 Series Performance Data

MODEL NUMBER		309CDC56/12		309DDC56/12	
HEAD CONFIGURATION		Pressure/Vacuum		Pressure	
STROKE		.560 Inches		.560 Inches	
PRESSURE		Flow @ 12V		Flow @ 12V	
cfm @ psi	l/min @ bar				
psi	bar	cfm	l/min	cfm	l/min
0	0	0.85	24.0	0.81	23.0
20	2	0.70	18.4	0.70	18.4
40	4	0.60	15.5	0.61	15.2
60	6	0.53	12.7	0.54	12.7
80	8	0.45	11.0	0.48	11.3
100	10	0.42	9.3	0.43	
120		0.37		0.39	
140		0.34			
MAX. CONTINUOUS PRESSURE		—	—	—	—
MAX. INTERMITTENT PRESSURE		160 psi	11.0 bar	134 psi	9.25 bar
MAX. DUTY CYCLE (MINUTES ON/OFF AT 23°C and 100 PSI)		36% (13 on / 23 off)		30% (8 on / 19 off)	
VACUUM		Flow @ 12V DC		Flow @ 12V DC	
cfm @ in.Hg	l/min @ mbar (gauge)				
in.Hg	mbar (gauge)	cfm	l/min	cfm	l/min
0	0	0.75	21.2		
5	-100	0.61	18.9		
10	-200	0.48	16.7		
15	-400	0.34	11.9		
20	-600	0.21	7.6		
25	-800	0.09	3.4		
MAX. VACUUM		26.75 in.Hg	904.1 mbar	—	—
MAX. AMBIENT AIR TEMP.		158° F	70° C	158° F	70° C
MIN. AMBIENT START TEMP.		-40° F	-40° C	-40° F	-40° C
MAX. RESTART PRESSURE		160 psi	11 bar	160 psi	11 bar
MAX. RESTART VACUUM		—	—	—	—
MOTOR VOLTAGE/FREQUENCY		12V DC		12V DC	
MOTOR TYPE		Permanent Magnet		Permanent Magnet	
CURRENT AT RATED LOAD (AMPS)		13.5		13.5	
POWER AT RATED LOAD (WATTS)		162		162	
STARTING CURRENT (LOCKED ROTOR, AMPS)		67		67	
CAPACITOR VALUE		-		-	
MIN. FULL LOAD SPEED (RPM)		2300		2300	
THERMAL PROTECTOR		Yes		Yes	
NET WEIGHT		5.1 lbs.	2.3 kg	6.4 lbs.	2.9 kg

* Unit meets Radiated Emissions performance per 72/245 ECC 2006/28EC

Self-Declaration to Low Voltage Directive 72/23 for 12VDC per IEC EN60335-1

RoHS Compliant

The information presented in this material is based on technical data and test results of nominal units. It is believed to be accurate and reliable and is offered as an aid to help in the selection of Thomas products. It is the responsibility of the user to determine the suitability of the product for his intended use and the user assumes all risk and liability whatsoever in connection therewith. Thomas Industries does not warrant, guarantee or assume any obligation or liability in connection with this information.

NOTE: Models pictured are representative of the series and do not represent a specific model number. Consult factory for detailed physical description.

Dimensions Millimeters are in []

309CDC

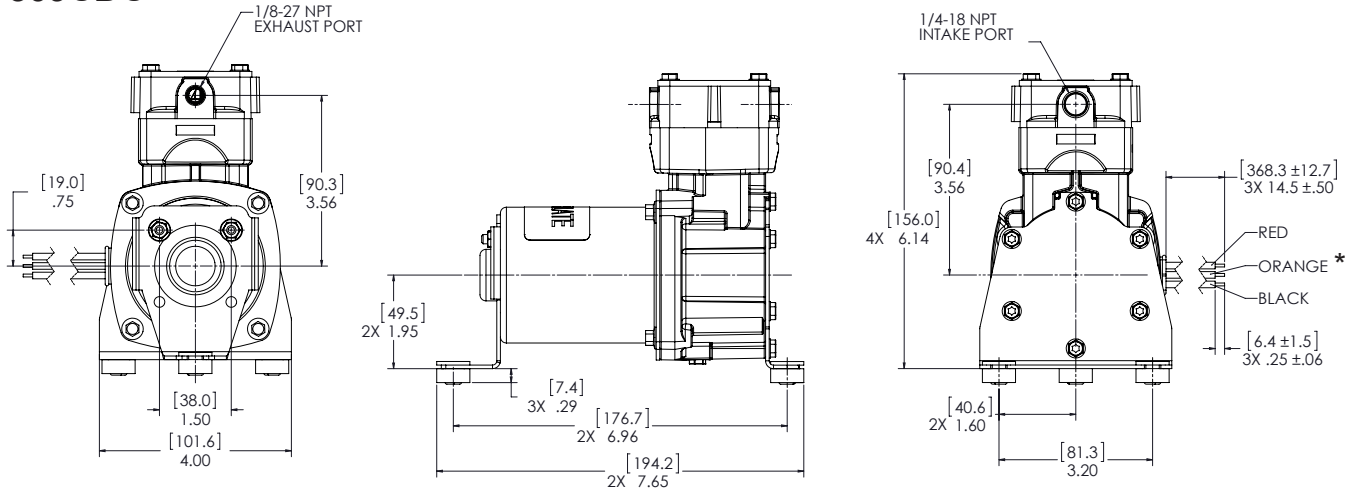

309DDC

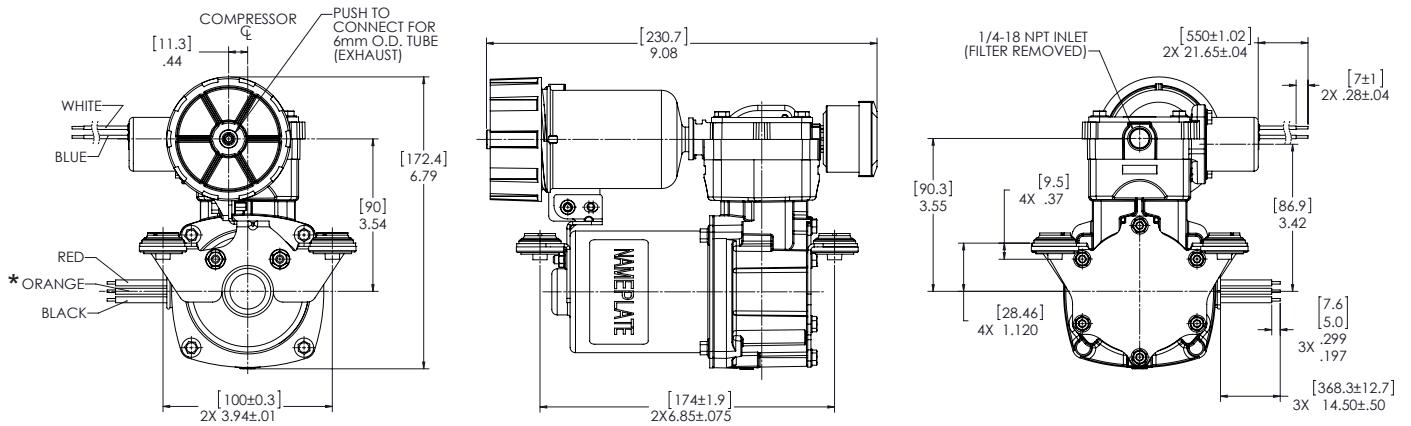

* denotes orange lead used to sense position of the thermal breaker (open/closed).

